



Main Features

- Intel® Atom™ processor E3827, 1.75GHz
- Dual SIM cards + dual WWAN modules support
- Built-in U-blox 6 GPS, optional Dead Reckoning support
- Built-in CAN 2.0B. Optional OBDII function (SAE J1939/ J1708)
- 4x mini-PCIe expansion
- Wake on RTC/ SMS via WWAN module
- Compliant with MIL-STD-810G
- Built-in G-sensor, Gyroscope, and e-Compass sensors

Product Overview

VTC 1010 features next generation Intel® Atom™ processor E3827, 1.75GHz, with powerful graphic and multimedia enhancement. VTC 1010 is packed rugged, fanless, and 1 DIN compact enclosure. It is specifically designed to comply with stringent MIL-STD-810G military standard. VTC 1010 comes with built-in CAN BUS 2.0B interface and optional OBDII (ASE J1939/ J1708) port to monitor the vehicle operating status real-time and trouble-shoot a non-working vehicle. With dual SIM cards design, it allows the choice of the best service carrier network and minimizes roaming cost. VTC 1010 can be configured to work with two independent WWAN connections and can effectively increase the bandwidth for faster massive data transfer over the air. VTC 1010 also supports two-way voice communication. Equipped with intelligent vehicle power management, VTC 1010 can be waked up by ignition, timer, or remote dial-up for flexible operation or maintenance. VTC 1010 can satisfy different demands for versatile telematics applications, such as infotainment, fleet management, dispatching system and mobile video surveillance.

Specifications

CPU

- Intel® Atom™ processor E3827, Dual Core 1.75GHz

Memory

- 1 x 200-pin DDR3L SO-DIMM socket support 1066MHz/ 1333MHz up to 8GB. Default 2GB

Storage

- 1 x 2.5" SATA 2.0
- 1 x SD card socket

Expansion

- 1 x full size Mini-PCIe socket (USB 2.0)
- 1 x full size Mini-PCIe socket (USB 2.0+ PCIe)
- 1 x full size Mini-PCIe socket (mSATA or PCIe)
- 1 x half size Mini-PCIe socket (USB 2.0 + PCIe)

Function

- 1 x default U-blox UBX-G6010 GPS module (50-channel and GALILEO) or optional modules with Dead Reckoning or GLONASS support
- Built-in G-sensor, Gyroscope, and e-Compass sensors

I/O Interface-Front

- 8 x LED for power, system status, storage, WWAN, WLAN, GPS, LAN, GPIO
- 2 x external accessible SIM card socket (selectable) with cover
- 1 x audio jack 3.5mm for WWAN voice communication, including 1 x Mic-In and 1 x Line-Out
- 1 x external accessible SD card socket with cover
- 1 x event button (trigger type)
- 1 x reset button
- 1 x type A USB 3.0 compliant host, supporting system boot up

I/O Interface-Rear

- 1 x 9~36VDC input with Ignition
- 1 x type A USB 2.0 compliant host, supporting system boot up
- 1 x RJ45 10/100/1000 Fast Ethernet with LED
- 1 x phone jack 3.5mm for 1 x Mic-In (for WWAN voice communication)
- 1 x phone jack 3.5mm for 1 x Line-Out (for PC audio)
- 1 x DB-15 VGA. Resolution up to 2560 x 1600 @60Hz
- 1 x DP port. Resolution up to 2560 x 1600 @60Hz
- 1 x DB-9 for RS-232
- 4 x antenna hole for GPS/ WWAN/ WLAN/ BT

Dimension Drawing

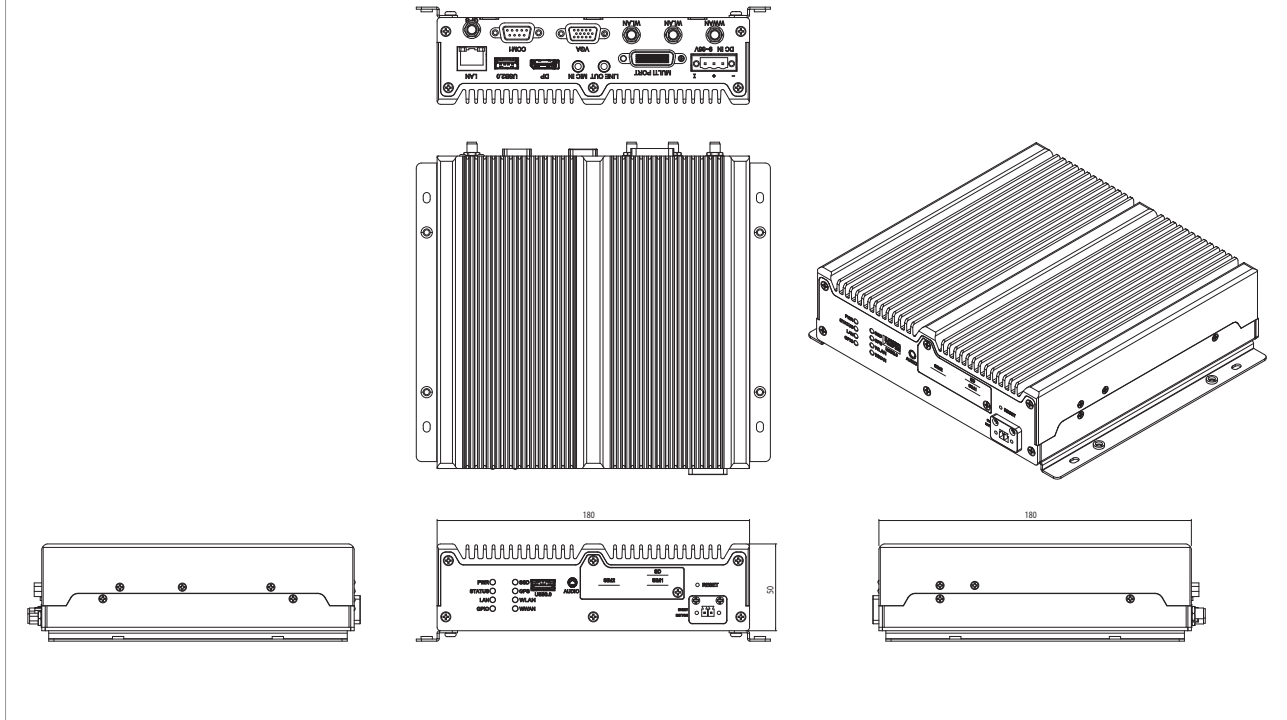

- 1 x LHF 60-pin connector
 - 1 x 6-pin power connector, 12VDC output (max: 1A)
 - 1 x type A female USB 2.0 compliant host, supporting system boot up
 - 1 x DB-9 RS-232
 - 1 x DB-9 RS-422/ 485
 - 1 x DB-9 female 3 x DI and 3 x DO. On board CAN 2.0B signals (Programmable Digital Input)
 - Input Voltage (Internal Type): 5VDC TTL (default)
 - Input Voltage (Source Type): 0~30VDC
 - (Programmable Digital Output)
 - Digital Output (Sink Type): 5VDC TTL (default), max current: 20mA
 - Digital Output (Source Type): 0~30VDC, max current: 250mA
 - 1 x DB-9 for optional ODBII module (ASE J1939 or J1708)
 - 1 x DB-9 for optional GPS Dead Reckoning module
 - 4 x BNC connector Video-In for optional 4-channel video capture card
 - 4 x audio connector for 7.1 channel audio output (front, center/ woofer, rear surround, side surround)

Power Management

- Selectable boot-up & shut-down voltage for low power protection by software
- Setting 8-level power on/ off delay time by software
- Status of ignition and low voltage can be detected by software
- Support S3/ S4 suspend mode

Operating System

- Windows 8 Professional, WES8
- Windows 7, WES7
- Tizen IVI

Dimensions

- 180 mm (W) x 180 mm (D) x 50 mm (H) (7.09" x 7.09" x 1.97")
- 1.7kg

Construction

- Fanless
- Aluminum fin top cover and front/ rear panels.
- SECC bottom enclosure

Environment

- Operating temperatures: Ambient with air: -30°C to 70°C
- Storage temperatures: -35°C to 85°C
- Relative humidity: 10% to 90% (non-condensing)
- Vibration (random): 1g@5~500 Hz (in operation, SSD)
- Vibration (SSD):
 - Operating: MIL-STD-810G, Method 514.6, Category 4, common carrier US highway truck vibration exposure
 - Storage: MIL-STD-810G, Method 514.6, Category 24, minimum integrity test
- Shock (SSD):
 - Operating: MIL-STD-810G, Method 516.6, Procedure I, functional shock=20g
 - Non-Operating: MIL-STD-810G, Method 516.6, Procedure V, crash hazard shock test=75g

Certifications

- CE approval
- FCC Class B
- E13 Mark

Ordering Information

- **VTC 1010-IVI (P/N: 10V00101001X2)**
Intel® Atom™ processor E3827 1.75GHz CPU, 2GB DDR3L SO-DIMM, VGA/DP Output, 1 LAN, 2 x RS-232, 1 x RS-422/485, 3 x DI, 3 x DO, 3 x USB, 12VDC output