

# pre-drupa media conference



# Veralto™

環境の持続可能性に重点を置き、重要な資源を  
守る、13の事業会社と16,000人の従業員  
からなるグローバルチーム



# Islands of automation

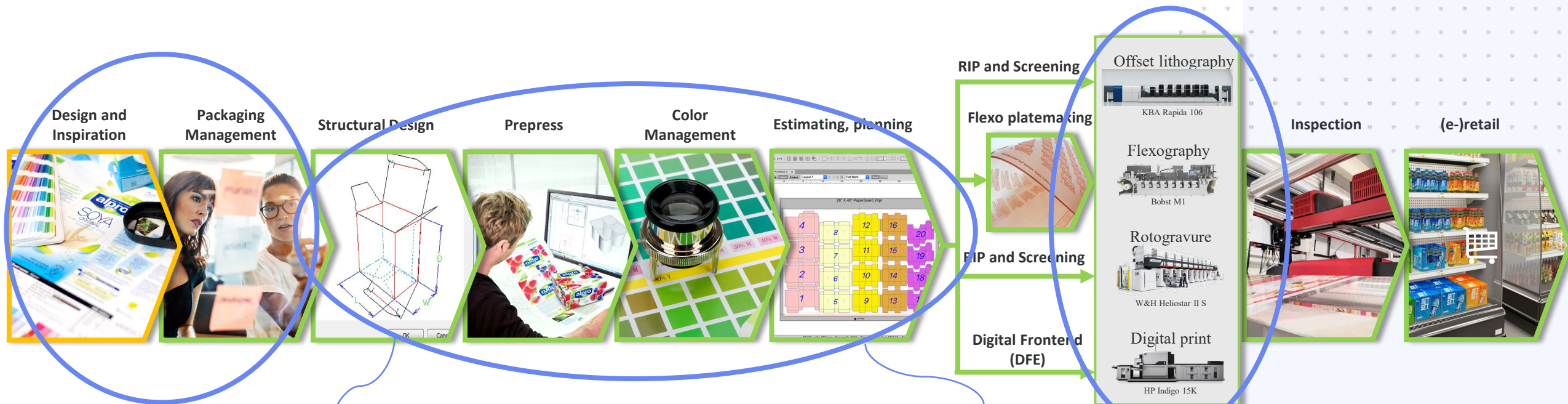

- Sharing jobs **between sites** (Jobの共有)

- Prepress connecting with **other departments** (プリプレスの連携)

- Brand Owners connecting **with their suppliers** (ブランドとサプライヤーのつながり)

- Connecting the print **production shopfloor** (印刷現場のコネクション)

# 大規模なカスタマイズ



## Benefits

- ブランドオーナーは、あらゆるパッケージに対して大量のカスタマイズされたパッケージを使用して、真の消費者エンゲージメントに取り組みが可能
- コンバーターは大量のカスタマイズされたパッケージングプロジェクトの生産プロセスを簡素化



# our drupa



Hall 8b A12

ENFOCUS

x·rite

PANTONE®

esko



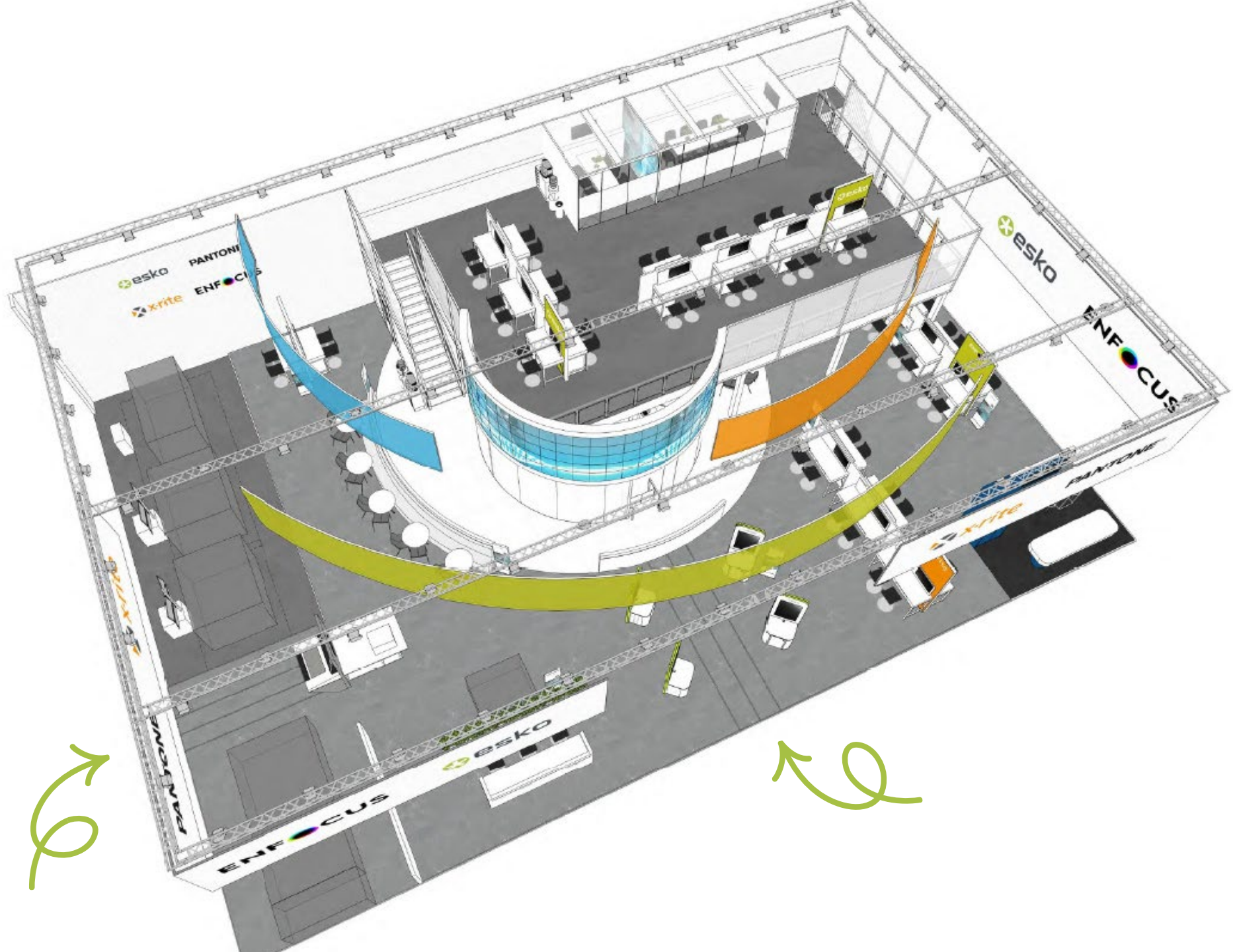

Hall 8b A12

# Innovation Lab

- パッケージワークフローのビジョンを共有
- 機能性を確認できるプロトタイプ
- 6つの可能性を体験



Innovation Lab – concept image





Stand out with  
**Packaging**



Stand out with  
**Color Accuracy**



Stand out with  
**Innovation**  
drupa 2024  
Hall 8B / A12



Stand out with  
**Color**



Stand out with  
**Automation**





# Innovation highlights



ENFOCUS

x·rite

PANTONE®

esko

# Introducing Esko sCloud

## Connected Products



## Integrated Products



## Native Products



## My Devices

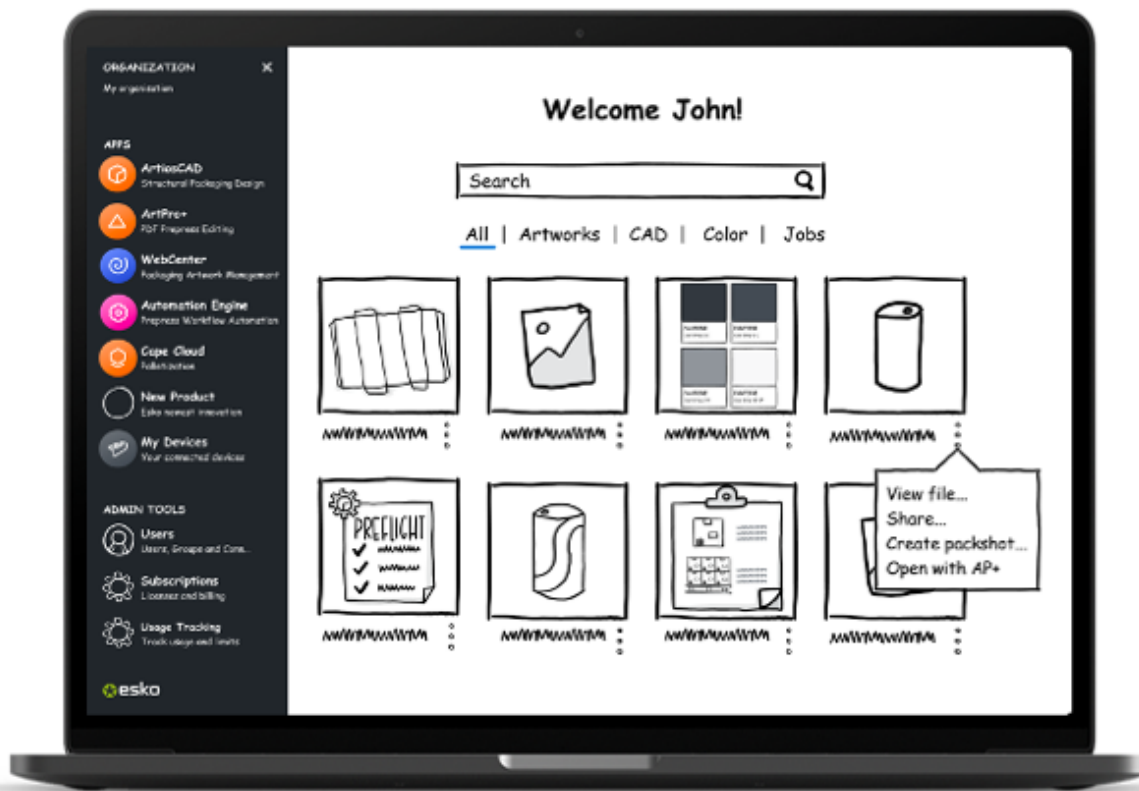

## sCloud Drive

一元的なデータ管理と統合された検索, 最新の AI 機能を使用して資産を再利用

## Administration Tools

ユーザー管理、アクセス権、ライセンス割り当てなどの管理

# Job Onboarding

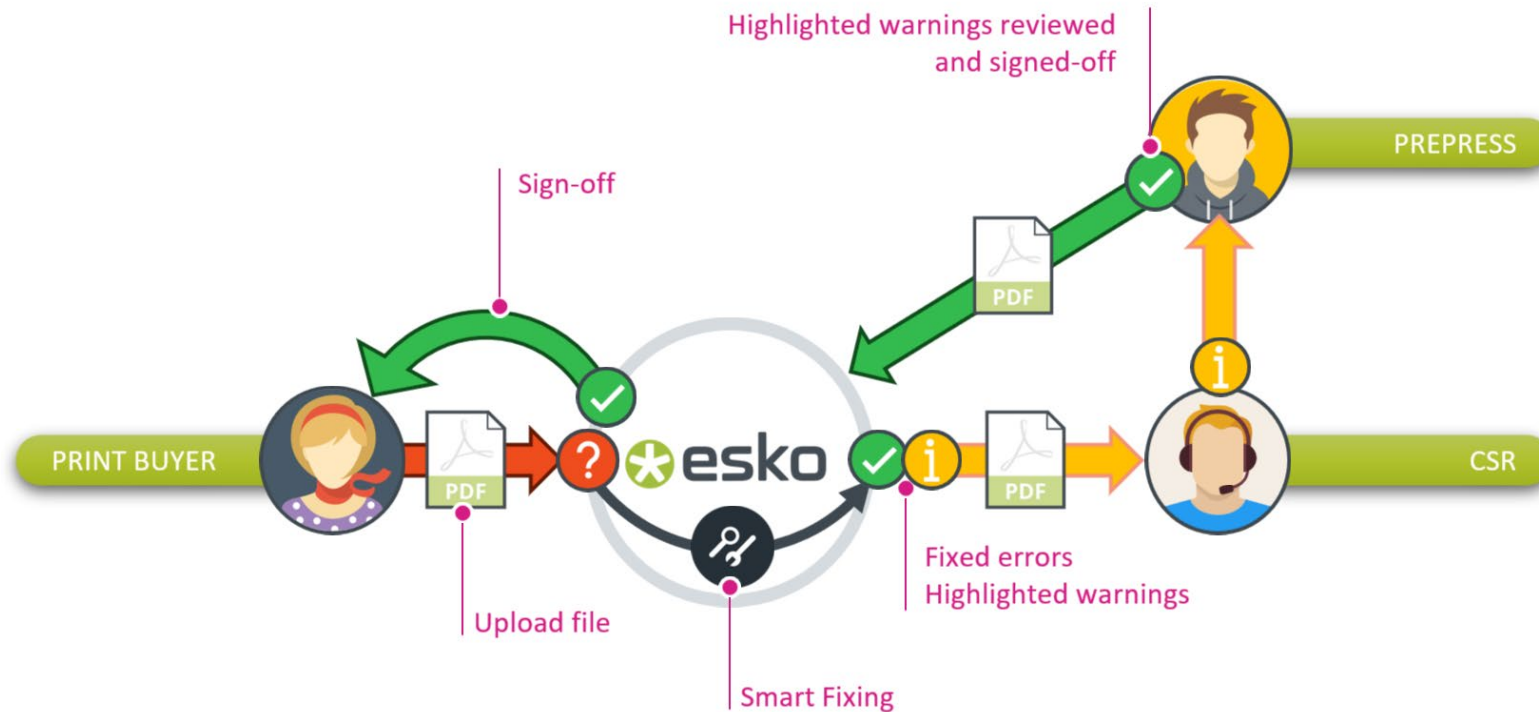

Esko sCloud ネイティブ アプリケーションは、見積り依頼 から承認まで、パッケージングバイヤーとコンバーター間のオンラインコミュニケーションを合理化。サイクルタイムを2日に短縮し、CSRが1日に処理するジョブの数を50%増加

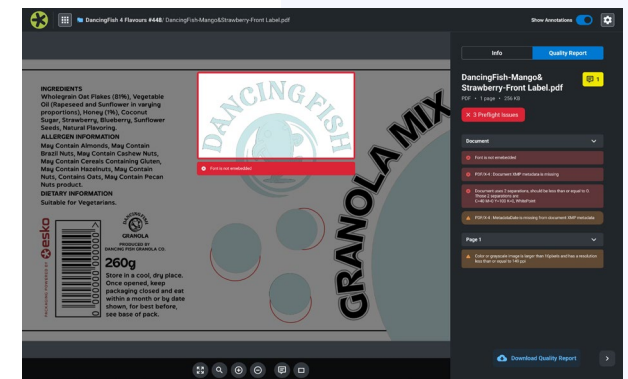
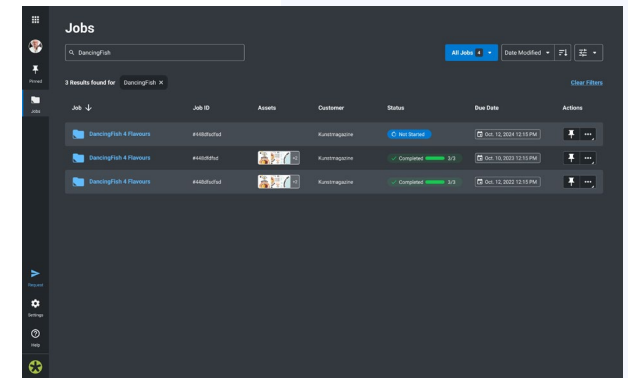
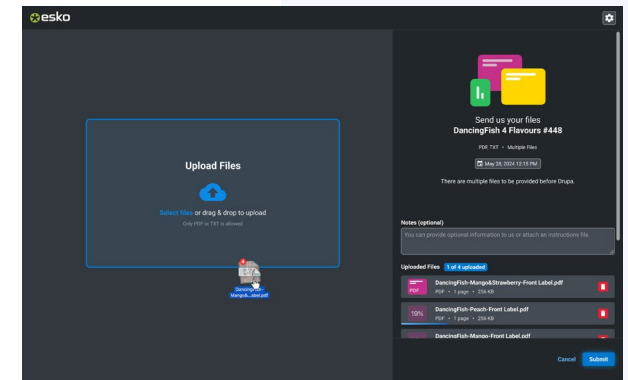



# Autura Ink

Reduce the Risk of Error



Quickly Share  
Formulation & QC Data



Efficiently Manage  
Ink Assortments



autura

Identify Ink  
Color Variation



Avoid Press Downtime



Serverless and Secure  
Cloud-Based Architecture



- インクの調合と品質管理を統合するクラウドベースのプラットフォーム
- 処方、保管、承認、検索、品質管理のあらゆる側面を合理化
- オフセット、フレキシ、グラビア、スクリーン印刷インキ



# PantoneLIVE Private Library Manager

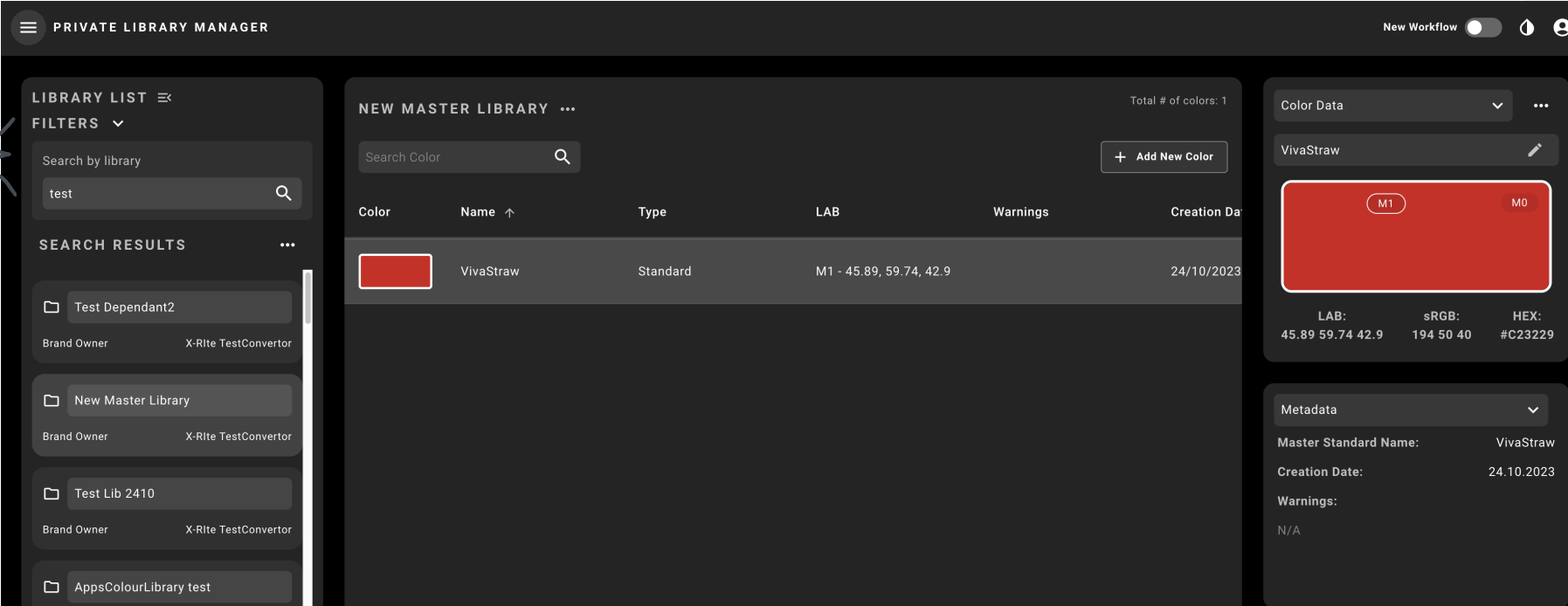

LIBRARY LIST 三  
FILTERS v

Search by library  
test

SEARCH RESULTS ...

- Test Dependant2  
Brand Owner X-Rite TestConvertor
- New Master Library  
Brand Owner X-Rite TestConvertor
- Test Lib 2410  
Brand Owner X-Rite TestConvertor
- AppsColourLibrary test

NEW MASTER LIBRARY ... Total # of colors: 1

Search Color

+ Add New Color

Color	Name ↑	Type	LAB	Warnings	Creation Da
	VivaStraw	Standard	M1 - 45.89, 59.74, 42.9		24/10/2023

Color Data v ...

VivaStraw

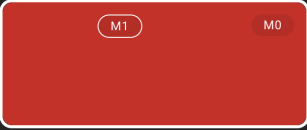

LAB: 45.89 59.74 42.9 sRGB: 194 50 40 HEX: #C23229

Metadata v

Master Standard Name: VivaStraw  
Creation Date: 24.10.2023  
Warnings: N/A

- 製品およびコミュニケーション全体にわたって綿密な色の均一性を追求するパッケージング・ブランドがターゲット
- さまざまな印刷技術やインクタイプを使用して、さまざまな基材上でブランドカラーを再現するために、生産全体を通して純粋なスペクトル値を活用する。

# ColorCert Scorecard Server 2.0



- 完全にカスタマイズ可能なダッシュボード
- 詳細なJob情報
- 直感的なJob比較ツール
- 包括的なレポート

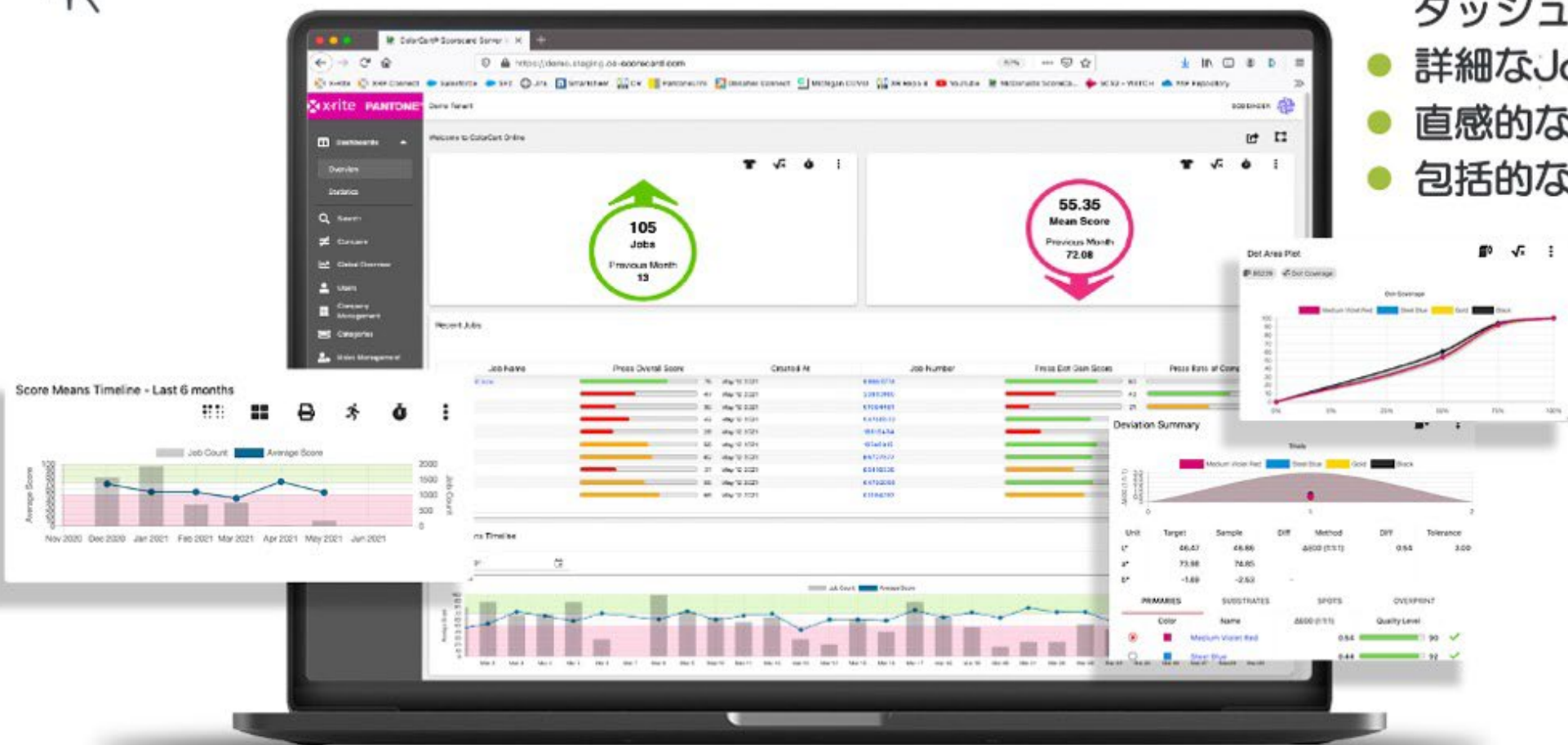



# CDI Crystal – Quartz Edition

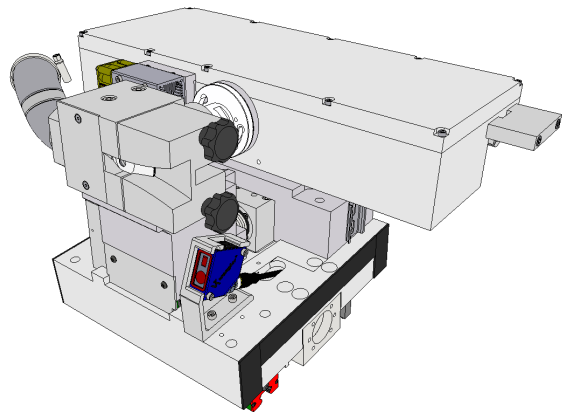

Solid, no surface structure



Microcells



Crystal screens with Q-Cells

ビームバランスとフォーカスサーチをデジタル化したクォーツ光学系で最大30%の高速化を実現 → 生産性を30%向上

Qセルによるクリスタルスクリーニング：

- アニロックス量を減らしてインキ使用量を減らし、印刷速度を向上
- 最高品質のクリスタルSQスクリーニングで拡張ガモット固定パレット印刷に最適化



# AVT Varnish Inspection Module

## フレキシブルパッケージとラベルのニス検査システム

- ラベルの確認のために印刷機を止める必要がない
- 蛍光UV添加剤の添加が不要
- 通常の印刷検査と一緒にニス検査を実施



varnish misregister detection



(partial) varnish starvation







# Wrap-up

## Market challenges

経済的不安  
市場投入までのスピード  
持続可能性

## New technological reality

クラウド・コンピューティング  
人工知能  
データ・コネクティビティ

## Next generation of workflow technology

Automate (自動化)  
Connect (接続)  
Accelerate (加速)

